



S80.29 SMART MODULATING HI SPEED 708 in.lbs



Model: S80.29 708 in.lbs SMART MODULATING HI SPEED ACTUATOR

	AC	AC/DC	DC
Rated Voltage	AC230V	AC/DC 24V	24VDC
Voltage Range	AC 95-265V/DC100-300V	AC18-26/DC22-32V	DC22-32V
Consumption	18W run, 2.1W hold	15W run, 2.1W hold	15W run, 2.1W hold
Peak current	0.52A @ 5ms 230V	4.5A @ 5ms 24VDC	4.5A for 5ms 24VDC
Fuse	2A	10A	10A
Maximum Break Torque in.lbs	796 / 90 Nm		
Run & Reseat Torque in.lbs	708 / 80 Nm		
Manual operation	Yes, by hexagonal wrench (supplied in clip) when no power. Local control via touch buttons under power.		
Control Signal Input/ Output	0-20mA, 4-20mA, 0-5V, 1-5V, 0-10V, 2-10V		
Run time	≈ 5 sec		

STANDARD FEATURES:

Operating Frequency	AC not continuous, 75% duty cycle but recommend allowing ≥ 1 min between cycles. DC is continuous.
Position Confirmation	Mechanically driven dome style visual 2 color indicator
Mounting Restriction	None, it can be mounted at any angle. Leave space for manual operation and electrical connection.
End Position Indication	Micro-switches operated by adjustable internal cams, set slightly ahead of the final motor stop position.
ISO:5211	F05 & F07
Working Angle	Factory set at $90^\circ \pm 2^\circ$, maximum angle of rotation $110^\circ \pm 2^\circ$
Female Drive	.67" (17mm) octagon x .83" (21mm) deep
Ingress Protection	IP67
Max Media Temperature	176° F
Ambient Temperature	-4° F to 176° F
Non-operating Temperature	-40° F to 176° F
Ambient Humidity	5-95% RH non-condensing
Explosion Proof	Actuator is not explosion proof and should not be placed in hazardous areas.
Housing	Plastic (ABS) cover
Weight	Standard ABS housing 4.85lbs

NOTE: With Series 80-110 you can select your Modulating Control (ex 4-20Ma or 0-10V) via the menu system. You can also select Normally Open, Normally Closed or Keep Position on signal loss. See the User Guide for more details.



+1 888-689-8258 • info@basiks.us

www.basiks.us

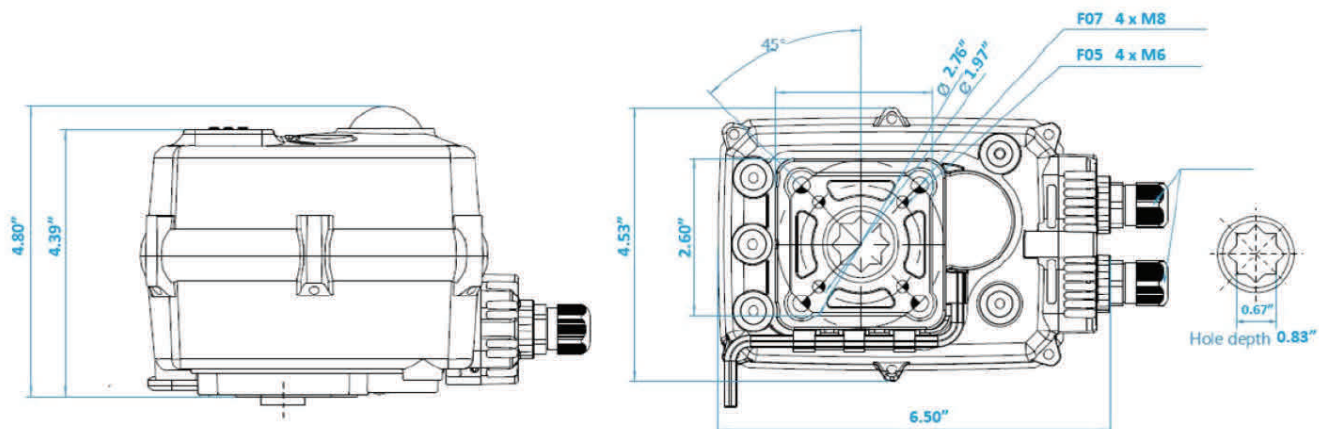

MATERIALS

S80.29 708 in.lbs SMART MODULATING HI SPEED ACTUATOR

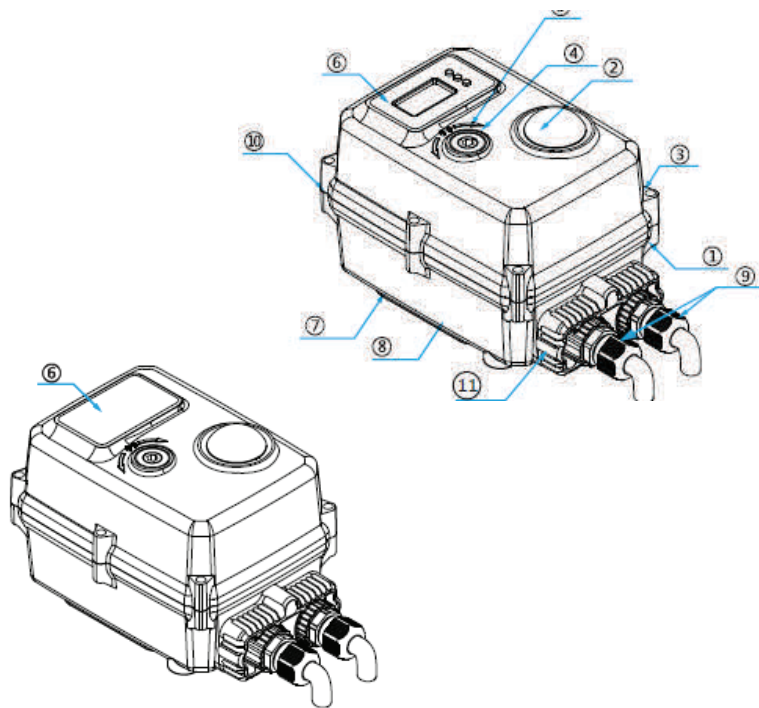

No	PART	MATERIAL
1	Housing	ABS
2	Indicator	Transparent AS
3	Cover screws	304SS
4	Override drive	304SS
5	Seal	NBR
6	Screen	OLED
7	Seal	NBR
8	Connector	Plastic
9	Cover seal	NBR
10	Seal	NBR
11	Label	PVC
12	Allen key	Tool steel
13	Terminal box	Heatproof ABS
14	Output drive	304SS

Part Numbers:

S80.29 708 in.lbs SMART MODULATING HI SPEED ACTUATOR

Model	Voltage	Housing	Heater	Control of Modulating function
S80.29-	5 AC 95-265V	P ABS	H 5W/24kΩ	P 4/20mA input / Output
	6 AC/DC 24V			U 0-10V input / Output

MODULATING WIRING TYPE 'P'

Without alarm signal output function

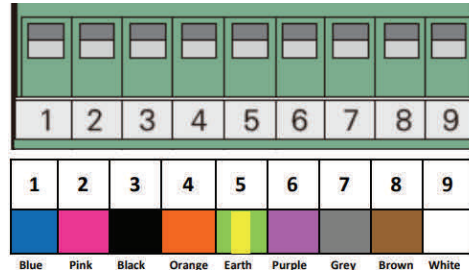
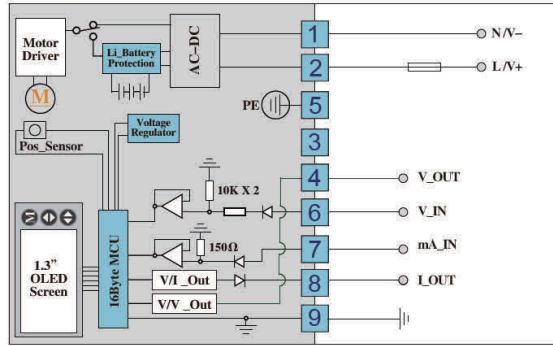

Volt free aux contacts

NOTE: ACTUATORS SHOULD HAVE DEDICATED POWER AND CONTROL

Overview: All Basiks smart electric actuators have local controls as standard. An OLED screen and 3 positive push buttons create a user friendly interface for local control and a variety of adjustments. The screen is easy to read, with bright blue letters on a black background, and the use of the push buttons to adjust settings is intuitive. The local controls require power to be applied to the actuator to operate.

Local controls:

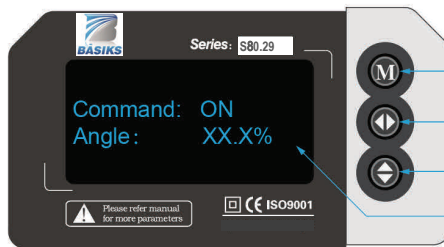

M button is used to enter and switch menus (Hold for three seconds).

K2 is used in conjunction with K3 for adjusting the actuator settings.

K3 is used for changing settings, navigating menus, exiting and saving.

OLED Screen with clear blue letters against a black background.

Standard local control function options:

- MANUAL CONTROL** The Basiks smart actuator can be opened and closed using the K2 and K3 buttons (hold down K3 for three seconds to access).
- DEAD BAND** Adjusts the accuracy and sensitivity of the actuator.
- SPEED CONTROL** The working time can be increased either by setting a step timer (run/stop/run/stop), or continuous running by adjusting the PWM.
- CLOSED POSITION** The close position of the actuator can be adjusted by using the K2 and K3 buttons (zero adjustment).
- REVERSE ACTING** Actuator closes when an open signal is received, and vice versa.
- EXTEND ANGLE** Adjust the open position by adjusting the span of the actuator. Typically used to set 0-180 degree operation.
- SIGNAL LOSS** Sets one of three positions the actuator takes at loss of signal control.
- CURRENT ADJUST** Adjust the output current of the actuator.