

BASIKS

Miniature Thermoplastic Diaphragm Seals/ Gauge Guards

Features / Advantages:

- Diaphragm Seals provide a protective barrier between process fluids and instruments.
- Increase product reliability and reduce system downtime caused by instruments failure.
- $\pm 4\%$ accuracy.
- Simple to fill and install.
- Hermetically sealed uni-body construction avoids possibility of dangerous leaks.
- For highly aggressive or ultra-pure liquids.
- Diaphragm safety – If the instrument is damaged or is removed while the system is pressurized, the diaphragm will automatically seal against leakage to the atmosphere.
- Polypro bodies for excellent chemical compatibility and temperatures up to 185°F (85°C).



Transducer

Materials of Construction

Instrument side (upper housing) is glass-filled polypropylene. System side (lower housing) is natural polypropylene. Diaphragm is available in either Viton® or Buna-N.

Design

Each GGME Gauge Guard features a durable and flexible diaphragm which serves as a protective barrier between the process fluid and instrument. The internal space on the instrument side of the diaphragm must be solidly filled with a suitable liquid in order to accurately transmit the process pressure to the instrument. Diaphragm Seals are designed for a maximum working pressure of 200 PSI (13.8 bars).

Compact size and economy price make the GGME ideal for systems requiring large quantities of pressure gauges, transducers and other small instruments such as pressure switches.



BASIKS

888-689-8258

www.basiks.us

info@basiks.us

Installation

When Series GGME Diaphragm Seals are purchased with a gauge, install the assembly by simply connecting it to the process piping using PFTE tape or other acceptable pipe sealant to effect a seal. The assembly need only be made hand tight followed by a one-quarter turn more with a strap wrench. Do not overtighten or breakage will result. Do not use pipe wrenches.

When purchased without a gauge, consult Installation Instruction Card provided with each GGME Diaphragm Seal.

For filling Diaphragm Seals ordered without a gauge, fill liquid is available in 4 ounce bottles.



Suitable for a variety of pressure instruments

MAXIMUM PRESSURE RATING		
TEMPERATURE		LIQUIDS
°F	°C	PSI (Bars)
70-100°F	(21-38°C)	200 (13.8)
100-185°F	(38-85°C)	200 (13.8)

Maximum Temperature is 185°F

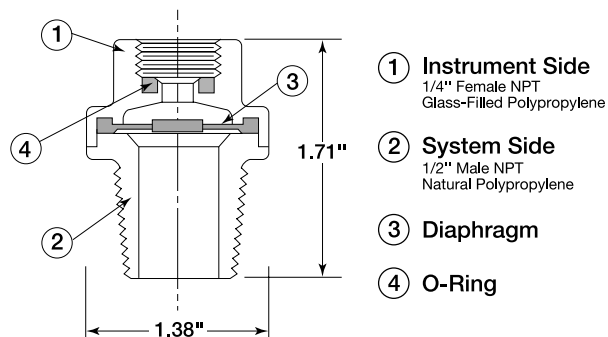

Ordering Information

Type of Service	Available Gauge Range (PSI (Bars))	System Side Materials	Diaphragm Materials	Gauge Guard Part Number
Pressure	Without Gauge	Natural Polypropylene	Buna-N Viton	GGMEB1-PP GGMEV1-PP
Vacuum	NOT FOR USE WITH VACUUM INSTRUMENTS			
Pressure	0-15 PSI (0-1.04 Bars)	Natural Polypropylene	Buna-N Viton	GGMEB015-PP GGMEV015-PP
Pressure	0-30 PSI (0-2.07 Bars)	Natural Polypropylene	Buna-N Viton	GGMEB030-PP GGMEV030-PP
Pressure	0-60 PSI (0-4.14 Bars)	Natural Polypropylene	Buna-N Viton	GGMEB060-PP GGMEV060-PP
Pressure	0-100 PSI (0-6.90 Bars)	Natural Polypropylene	Buna-N Viton	GGMEB100-PP GGMEV100-PP
Pressure	0-160 PSI (0-11.04 Bars)	Natural Polypropylene	Buna-N Viton	GGMEB160-PP GGMEV160-PP
Pressure	0-200 PSI (0-13.80 Bars)	Natural Polypropylene	Buna-N Viton	GGMEB200-PP GGMEV200-PP



888-689-8258

www.basiks.us info@basiks.us

A Value Line by Plast-O-Matic Valves, Inc. • 1384 Pompton Ave., Cedar Grove, NJ 07009 USA